

ASCO 7000 SERIES Soft Load Power Transfer Switches





Protecting data centers,
hospitals, airports, retail
stores and other facilities

The ASCO 7000 SERIES Closed-Transition Soft Load Power Transfer Switch gives you the flexibility to:

- Ensure the level of power reliability required by your operations or process
- Switch critical loads between live utility and onsite power sources seamlessly
- Maintain parallel operation of both power sources
- Assure emergency transfer operation upon utility power failure
- Satisfy a broad range of power applications
- Reduce energy costs by shaving your facility's peak energy demand
- Export/import power to/from the electric utility
- Capitalize on the benefits of remote command and control
- Manage energy use more efficiently





Whatever your application, the ASCO 7000 SERIES Soft Load Power Transfer Switch can meet your load transfer requirements with an unsurpassed range of features and benefits.



The ASCO 7000 SERIES Soft Load Power Transfer Switch:

- Seamlessly transfers loads between acceptable utility power and onsite generation with virtually no voltage or frequency transients
- Transfers power using proven ASCO Closed-Transition Transfer Switches (CTTS)
- Automatically selects emergency standby transfer operation upon loss of utility power
- Enables you to monitor and control soft load operation using GUIs (graphical user interfaces) with user-friendly, pull-down menus
- Actively synchronizes the onsite generating unit to the utility source by automatically adjusting the generating unit's governor and voltage regulator (analog or pulse width modulated outputs control the governor)
- Actively controls generator kW and power factor during parallel operation
- Contains protective functions on utility and generator sources required for ongoing parallel operation
- Allows you to activate protective functions using the touch screen (each function can be programmed to signal an external breaker and/or alarm signal, or just display the condition on the GUI)
- Maximizes security with multiple levels of password protection
- Records and time stamps events and all changes to protective function settings
- Provides digital inputs with adjustable trip and reset time delays to control or monitor external devices
- Is available in 150 – 4000 amperes
- Listed to UL 1008, the industry safety standard for transfer switch equipment



24-hour protection no matter when trouble strikes

Synchronizing Power Ensures Continuity

The ASCO 7000 SERIES Soft Load Power Transfer Switch synchronizes and parallels two independent power sources, without interrupting power flow. The switch can be programmed to either maintain parallel operation of both power sources, or transfer the load to the onsite generating unit, avoiding transients caused by block loading.

Coupled with Web-enabled ASCO *SiteWeb*® command and control, the Soft Load Power Transfer Switch enables you to use your onsite generation unit for soft load transferring, base loading, importing or exporting.

Soft Load Power Transferring

In the soft load power transfer mode, the transfer switch synchronizes and parallels the onsite generating unit to the utility source, then immediately instructs the generating unit to assume a preset load value (Gen Minimum Load Setpoint). The Soft Load Controller then continues to control generator excitation to the preset

power factor setting. It begins increasing load on the engine at a preset ramp time rate. At the point the load on the utility source drops to the cutoff value, the switch disconnects the utility feeder.

Continuous Base Loading

In the base loading mode, the generating unit operates continuously in parallel with the utility source until operation is discontinued on command. While operating, the soft load controller holds the load and power factor to the generating unit constant. Load variations are carried by the utility source. The switch retransfers the load to the utility source if the generating unit malfunctions.

Power Importing or Exporting

In the importing or exporting modes, the power transfer switch maintains the generating unit in parallel with the utility source. The switch's Soft Load Controller instructs the generating unit to produce the required output and varies the load on the unit to maintain the set import or export level. Load variations are carried by the generating unit up to the maximum generator load setting.

If either the utility or generator power fails in any of the modes, the load automatically transfers to the available source.

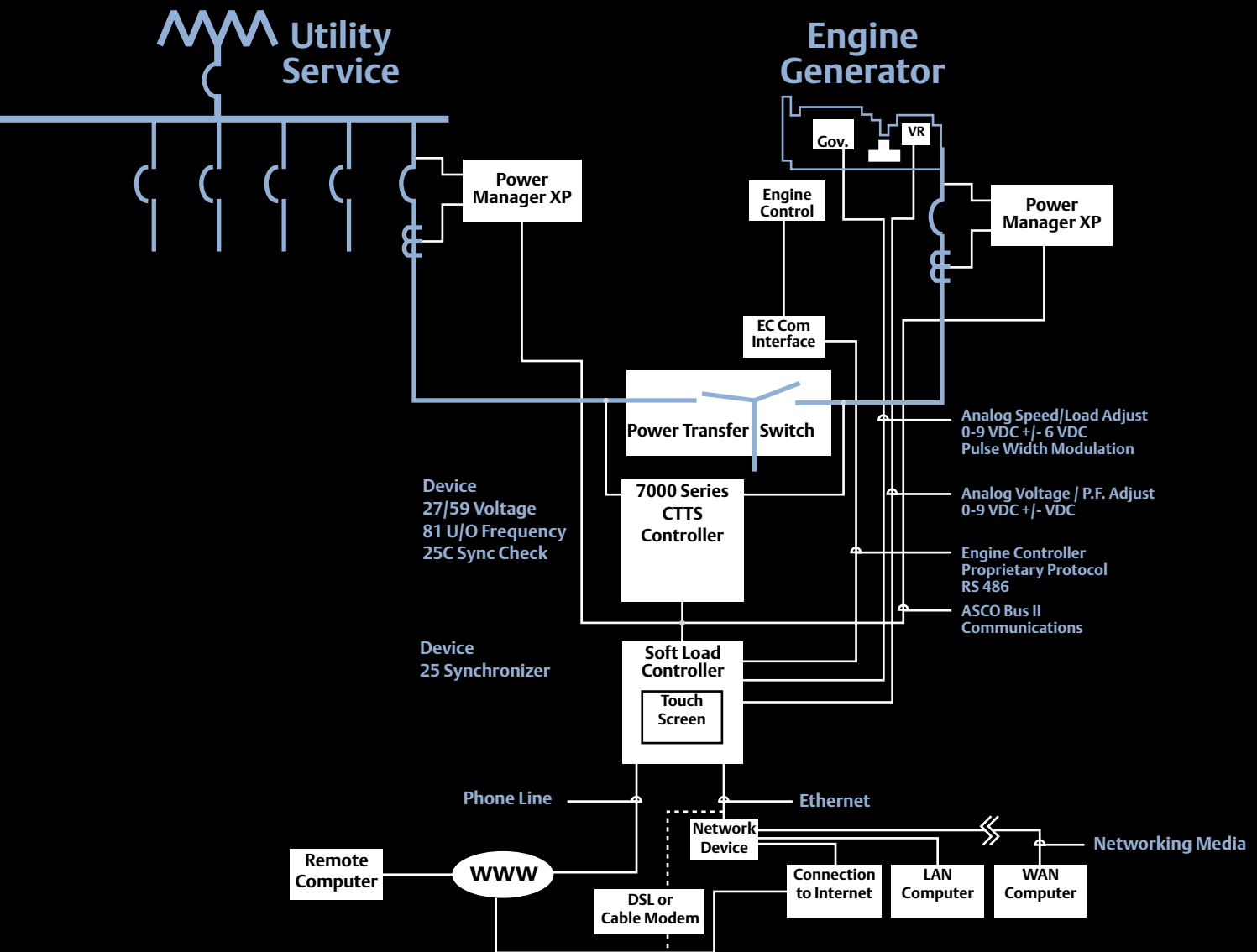

SiteWeb® enables remote communications

The transfer switch schematic illustrates communications paths that enable users to remotely monitor and control operation of the Closed-Transition Soft Load Power Transfer Switch with ASCO's exclusive SiteWeb® command and control interconnectivity. End users can monitor system status, load management settings, event logs and alarms from anywhere in the world, and receive e-mail paging for alarm signals. Communications paths include Internet, intranet, and/or Modbus networks via Ethernet, serial and/or DSL, or cable modem interfaces.



ASCO is the global leader in power switching and controls

ASCO 7000 SERIES Closed-Transition Soft Load Power Transfer Switch

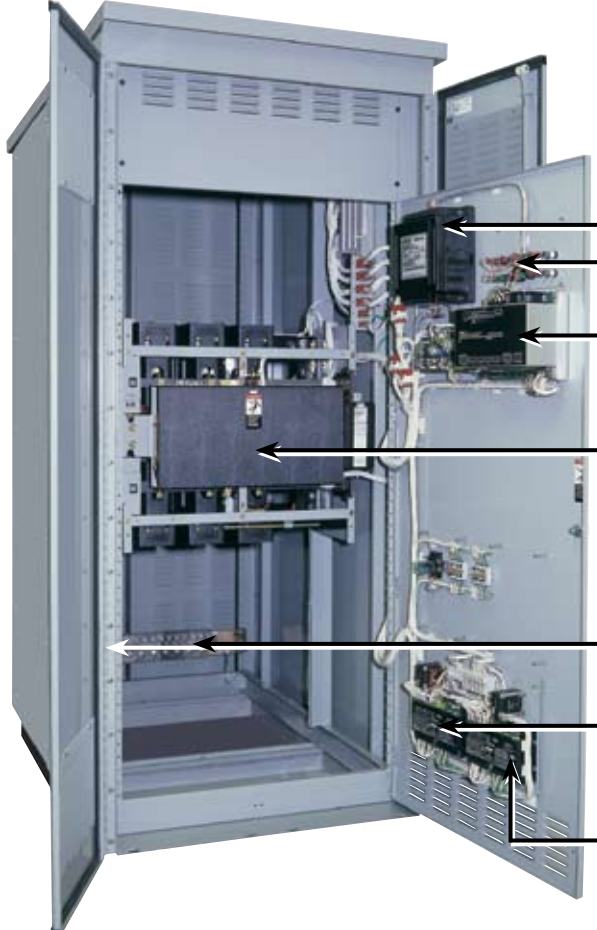

- 7000 SERIES Controller
- 7000 SERIES User Control and Indicator Panel
- 7000 SERIES Soft Load Controller
- Power Transfer Switch
- Ground Bus
- 5200 SERIES Power Manager XP (utility)
- 5200 SERIES Power Manager XP (generator)

Both the Closed-Transition Soft Load Power Transfer Switch and the Bypass-Isolation Soft Load Power Transfer Switch feature identical electrical ratings and heavy-duty mechanical interlocks that assure proper operation. The transfer switches feature a family of innovative electronic components that help make the switches the most advanced in the world.

Above switch rated 3000 amps in a Type 3R outdoor enclosure typically used with a 2 MW gen-set

ASCO power transfer switches—the standard of the industry—synchronize and parallel generation and utility power, allowing critical load transfers without momentary outages or surges.

Overlapping main electrical contacts using a reliable and field-proven solenoid

operating mechanism enable make-before-break transfers that help ensure continuous power. Control logic continuously monitors power source conditions and automatically determines whether the load transfer should be open (conventional, non-overlap mode), or closed transition. Failure to synchronize indication and

extended parallel time protection is built in to prevent abnormal operation.

7000 SERIES power transfer switches are available in ampacity sizes of 150–4000.

Maximum reliability & excellent value

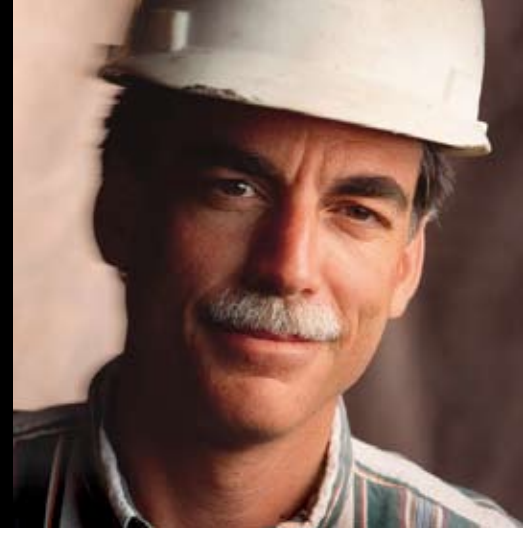

ASCO 7000 SERIES Soft Load Power Transfer Switch with Bypass-Isolation

Above Switch rated 2000 amps in a Type 3R outdoor enclosure

The ASCO 7000 SERIES Closed-Transition Soft Load Power Transfer Switch with bypass-isolation switching allows the switch to be inspected, tested and maintained without interrupting power, whether it's being provided from the utility or onsite generator.

A drawout mechanism power transfer switch helps ensure ease of service and maintenance. Simple bypass and isolation functions require only two operating handles. Bypass contacts carry current only during the bypass mode.

The bypass switch has dead front quick-make, quick-break operation for trans-

ferring loads between live sources. It is fully rated for use as a manual three-position emergency power transfer switch in the event of a utility power failure when the transfer switch is in the isolated position. It is available in ampacity sizes of 150 – 4000.



Creative, responsive, customer - focused and competitive.

Advanced Power Control and Monitoring

7000 SERIES Soft Load Controller



The Soft Load Controller is an industrial computer for controlling all soft load and parallel operation. The Controller communicates with the power transfer switch, controller, utility and generator Power Managers, engine-generator set controls, remote ASCO SiteWeb™ clients and facility supervisory control and data acquisition (SCADA) systems. This component:

- Actively controls engine generator output voltage and speed to synchronize the onsite power source with utility power (Device 25)
- Includes analog and PWM (pulse width modulated) outputs for controlling engine speed/loading and analog output for generator voltage/power factor
- Includes communication ports that provide Internet and intranet access for status checks and remote control
- Records and displays a time-and-date-stamped log of all system events and alarms (including those caused by protective trip functions)
- Includes a GUI (graphical user interface) for system set up, monitoring, and control

5200 SERIES Power Manager XP



Two Power Managers, one each dedicated to utility and onsite power sources, provide protective relay functions for reliable parallel operation of the sources. The power managers include digital inputs and outputs (Device 86).

In addition to directional power, a directional overcurrent device provides the most reliable protection against undesirable backfeeding of onsite power to the utility grid.

Utility Source Power Manager

- Device 27/59 Under and over voltage
- Device 32 Directional power
- Device 46 - Negative sequence overcurrent

Generator Source Power Manager

- Device 27/59 - Under and over voltage
- Device 32 - Directional power
- Device 40 - Loss of excitation (excess VARs)
- Device 81 - Under and over frequency
- Device 86 - Lockout relay

World-class technology for reliable power transfer



Control Interfaces

7000 SERIES User Control and Indicator Panel

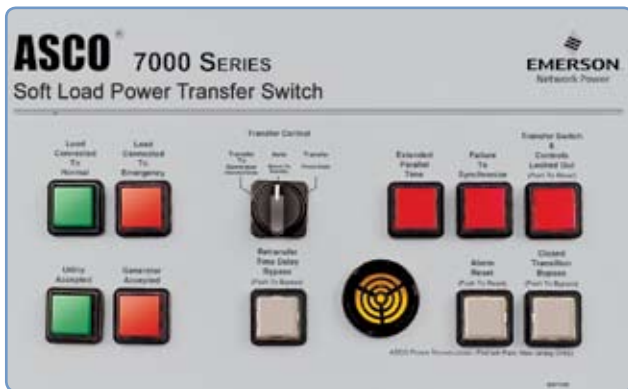

The panel organizes a three-position selector switch for “Auto,” “Soft Load Transfer” and “Transfer Preset” operation and LED status indicators.

AUTO is the normal setting for automatic soft load transfers initiated remotely.

SOFT LOAD TRANSFER manually selects the soft load mode of operation regardless of the settings in the soft load power transfer controller. The time in the parallel position is

based on the generator load/unload ramp time setting.

TRANSFER PRESET manually initiates a soft load power transfer based on the soft load controller settings (base loading, soft load transferring or importing/exporting).

Additional controls enable users to set bypass time delays and reset alarms.

Microprocessor-Based Controllers



The Controller—the most advanced digital controller in the industry—automatically starts the engine and controls load transfer to an onsite power source in the event of a utility power outage. If the onsite power source fails, it automatically transfers the load to the utility power source in an open transition mode.

It includes all voltage, frequency, control and timing functions required for emergency and standby power applications.

Touch pad programming establishes all operational settings and features, without the need for meters or variable power supplies.

On-board diagnostics provide control panel and automatic transfer switch status information to analyze system performance. Password protection prevents unauthorized use.

The microprocessor logic board is separated and isolated from the power board to improve electrical noise immunity performance and to help assure compliance with rigorous transient suppression standards. (See page 12 for standards compliance chart.)



Ensure continuous power for your operations

7000 SERIES Softload Graphical User Interface Panels

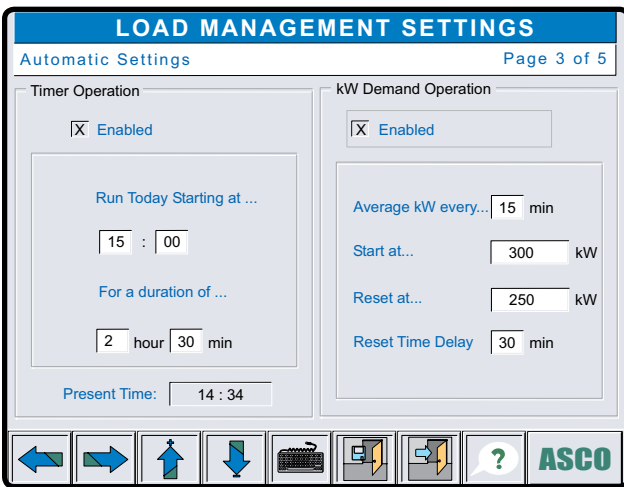

The intuitive, touch-screen GUI (graphical user interface) Panel displays at-a-glance operational status and enables users to set, monitor and control all functions quickly and easily. Menu bars simplify and speed navigation.

This screen shows that soft load transfer can be initiated automatically at a preset time or level of integrated kW demand. With a time-of-day setting, the operating mode would continue for a prescribed duration. With a kW demand setting, the operating mode would continue

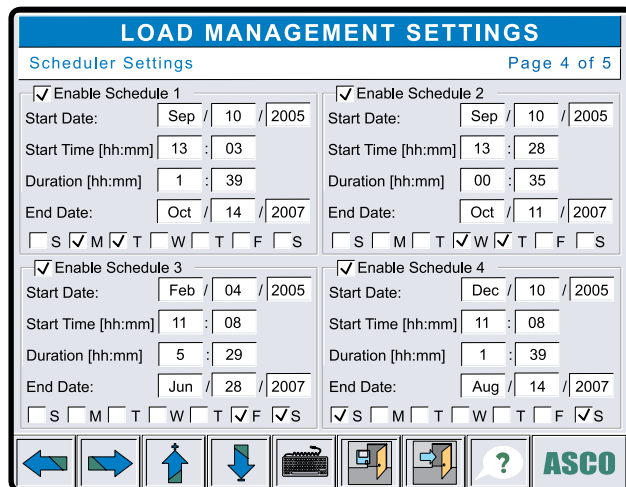

until kW demand dropped below the preset kW level. Selecting both time-of-day and kW integrated settings enables either setting to initiate operation, but both settings must be satisfied before operation can be terminated automatically.

The Home Screen, Source Summary Screen, Load Management Settings Screen and Event Log Screen illustrate the range of data available through the panel. More than 50 screens provide users with total control and access to information on every aspect of system operation.

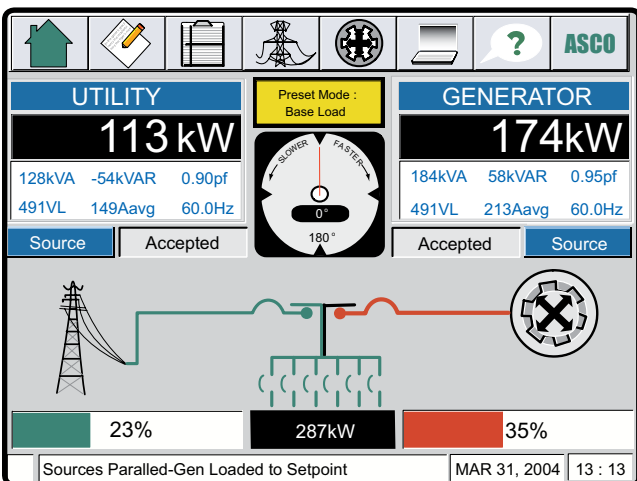

7000 SERIES Home Screen

This screen includes a synchroscope representation that shows the relative phase angle between the two sources of power. This screen also displays:

- Phase-to-phase voltage, frequency, current, kW, kVA and kVAR for each power source
- Percent of load being supplied from each source
- Load kW and system status
- Power transfer switch position
- Preset mode of operation
- Open or closed position of both power source breakers

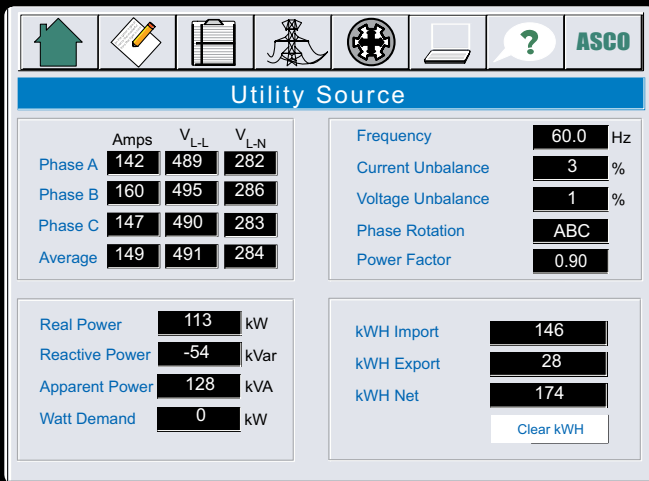

7000 SERIES Source Summary Screen

A screen for each power source shows detailed displays of a variety of electrical parameters:

- Phase voltage
- Frequency and power factor
- Utility source import and export kWh
- Power source kW, kVA and kVAR
- Phase voltages and currents, line-neutral voltages, average phase voltage and current
- Voltage and current unbalances

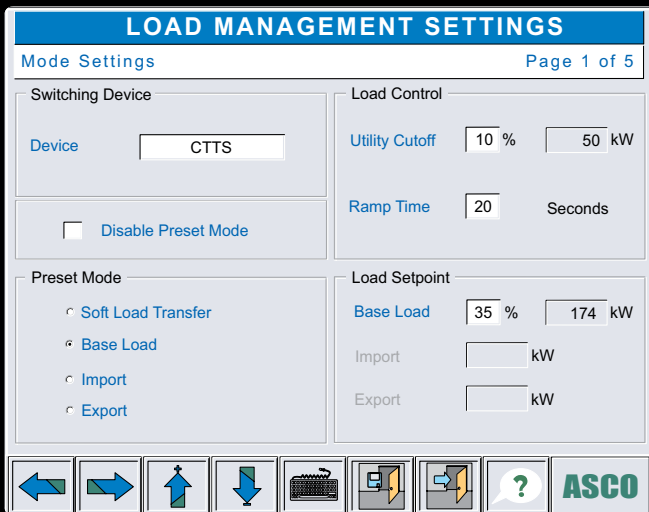

7000 SERIES Load Management Settings Screen

A series of system configuration screens, such as this one, enable users to set system parameters, protective control functions and eight programmable user inputs for alarming or signaling conditions of external devices. Multiple levels of password protection control access to the screens. Users can use this screen to set:

- System operation—soft load transferring, base loading or importing/ex-ported modes
- Soft load ramp time
- Utility power cutoff setpoint
- Base load kilowatt setpoint
- Import or export

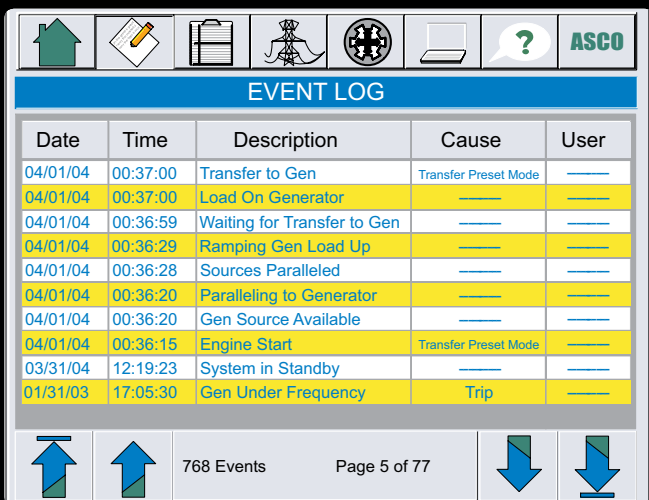

7000 SERIES Event Log Screen

This screen displays any of the last 1000 events that are automatically time-and-date stamped and saved in an historical database. The event log saves all user acknowledgements, including the ID of the acknowledging user. Event categories cover:

- Utility and onsite power source status, including tripping of protective functions, exceeding system setpoints, acceptance of permissive setpoints and status of user-defined discrete inputs, and feeder circuit breaker status
- Transfer switch status, including transfers to the onsite power or utility sources
- Engine generator status, including engine start/stop and user-defined engine alarms and shut-downs

Ordering Information

ASCO® 7000 SERIES

Closed-Transition Soft Load Transfer Switch

The sample catalog number below is 7ASLSA3400N5C

To order an ASCO 7000 SERIES Closed-Transition Soft Load Transfer Switch, use the following sample catalog number for the switch you want:

7	A	SLS	+	A	+	3	+	400	+	N	+	5	+	C
Product				Neutral Code*	Phase Poles	Amperes Code	Voltage Code	Grp	Cabinet					
A	Automatic	SLS	Soft Load Closed-Transition	—	No Neutral	3	150 260 400	C 208 D 220 E 230	5X-optional accessories	C	Type 1 enclosure			
		SLB	Soft Load W/Bypass-Isolation Switch	A	Solid Neutral	600	F 240			M	Type 3R secure enclosure			
				B	Switched Neutral	800	L 440							
				C	Overlapping Neutral	1000	M 460							
						1200	N 480							
						1600	P 550							
						2000 3000 4000	Q 575 R 600							

*Note: Specify neutral code B (optional) on switches rated 150-3000 amps and neutral code C on switches rated 4000 amps.

ASCO® 7000 SERIESMicroprocessor-Based
Controllers**Transient Suppression Standards Compliance**

Emission Standard – Group 1, Class A	FCC Part 15, Class A
Generic Immunity Standard, from which:	EN 50082-2:1995
Electrostatic Discharge (ESD) Immunity	EN 61000-4-2:1995
Radiated Electromagnetic Field Immunity	FCC Part 15, Class A
Electrical Fast Transient (EFT) Immunity	EN 61000-4-4:1995
Surge Transient Immunity	EN 61000-4-5:1995
Conducted Radio-Frequency Field Immunity	EN 61000-4-6:1996
Voltage Dips, Interruptions and Variations Immunity	EN 61000-4-11:1994

ASCO® 7000 SERIESClosed-Transition
Soft Load Transfer
Switch TerminalsSizes of UL-Listed Solderless
Screw-Type Terminals for
External Power Connections

Switch Rating Amps	Max. # of Conductors per Terminal	Range of AL-CU Conductor Sizes
150, 260, 400	One	#4 AWG to 600 MCM
600	Two	#1/0 AWG to 600 MCM
800 – 1200	Four	#1/0 AWG to 600 MCM
1600 – 2000	Six	#1/0 AWG to 600 MCM
3000 – 4000	Twelve	#1/0 AWG to 600 MCM

ASCO® 7000 SERIESBypass-Isolation
Soft Load Transfer
Switch TerminalsSizes of UL-Listed Solderless
Screw-Type Terminals for
External
Power Connections

Switch Rating Amps	Max. # of Conductors per Terminal	Range of AL-CU Conductor Sizes
150, 260, 400	One	#4 to 600 AWG
600 – 800	Three	#2 AWG to 600 MCM
1000 – 1200	Four	#1/0 AWG to 600 MCM
1600 – 2000	Six	#1/0 AWG to 600 MCM
3000	Ten	#1/0 AWG to 600 MCM
4000	Twelve	#1/0 AWG to 600 MCM

Dimensions

ASCO® 7000 SERIES

Closed-Transition Soft Load Transfer Switch Dimensions⁷

Switch Rating amps	Poles	Width inches (mm)	Height inches (mm)	Depth inches (mm)
Enclosed UL Type 1 (Consult ASCO for Type 3R dimensions.)				
150, 260, 400 ¹	3 or 3 with neutral A/B	24 (610)	56 (1422)	14 (356)
600	3 or 3 with neutral A/B	24 (610)	63 (1600)	17 (432)
800, 1000	3 or 3 with neutral A/B	34 (864)	72 (1829)	20 (508)
1200	3 or 3 with neutral A/B	38 (965)	87 (2210)	23 (584)
1600 – 2000 ²	3 or 3 with neutral A/B	38 (965)	91 (2311)	48 (1219)
1600 – 2000 ² (front connected)	3 or 3 with neutral A/B	38 (965)	87 (2210)	23 (584)
3000 ²	3 or 3 with neutral A/B	38 (965)	91 (2311)	60 (1524)
4000 ²	3 or 3 with neutral A/C	46 (1168)	91 (2311)	72 (1829)

ASCO® 7000 SERIES

Bypass-Isolation Soft Load Transfer Switch Dimensions⁷

Switch Rating amps	Power Connection Configuration	Poles	Width inches (mm)	Height inches (mm)	Depth inches (mm)
Enclosed UL Type 1 (Consult ASCO for Type 3R dimensions.)					
150, 200, 230, 260, 400, 600 ¹	Front Connected	3 or 3 with neutral A/B	34 (864)	85 (2159)	28 (711)
800 ^{1,4}	Front Connected	3 or 3 with neutral A/B	38 (965)	91 (2311)	32 (813)
800, 1000, 1200 ^{1,2}	Side/Rear Connected	3 or 3 with neutral A/B	38 (965)	91 (2311)	48 (1219)
1600 – 2000 ^{1,2}	Side/Rear Connected	3 or 3 with neutral A/B	38 (965)	91 (2311)	60 (1524)
3000 ^{1,2}	Side/Rear Connected	3 or 3 with neutral A/B	38 (965)	91 (2311)	72 (1829)
4000 ³	Rear Connected	3 or 3 with neutral A/C	96-1/2 (2451)	91 (2311)	72 (1829)

Notes:

- Handles extend 6-1/4 inches (159mm).
- Recommended clearance to enclosure: 3 feet (914mm) from rear, 4 feet (1219mm) from front (25 inches required for transfer switch drawout). Side or rear access required.
- For 4000 amp size, ATS and bypass sections can be reversed; contact ASCO. Recommended clearance to enclosure: 3 feet (914mm) from rear, 5 feet (1524mm) from front (3 feet required for transfer switch rollout).
- Conventional switched neutral is provided on 7A DTB and 7N DTB switching arrangements when specified (optional Code B).
- Specify optional accessory 40HY for 600 amp front-connected arrangement and 40JY for 800 amp. All service and load capabilities limited to top entry only.
- Contact ASCO for details.
- All dimensions shown are approximate and should not be used for construction purposes. Certified dimensions can be furnished upon request.

ASCO® 7000 SERIES**Closed-Transition Soft Load Transfer Switch Shipping Weights**

*(Export shipments may require a wooden box. Contact ASCO for weights and dimensions. Consult ASCO for Type 3R shipping weights.)

Switch Rating amps	Poles	Type 1* Enclosure
150, 260, 400	3	325 (148)
150, 260, 400	3 with B	335 (152)
600	3	425(193)
600	3 with B	435(198)
800, 1000	3	510 (231)
800, 1000	3 with B	540 (244)
1200	3	800 (362)
1200	3 with B	830 (375)
1600 – 2000	3	1410 (637)
1600 – 2000	3 with B	1460 (660)
3000	3	2210 (998)
3000	3 with B	2280 (1031)
4000	3	2640 (1193)
4000	3 with C	2740 (1238)

ASCO® 7000 SERIES**Bypass-Isolation Soft Load Transfer Switch Shipping Weights**

*(Export shipments may require a wooden box. Contact ASCO for weights and dimensions. Consult ASCO for Type 3R shipping weights.)

Switch Rating amps	Poles	Type 1* Enclosure
150, 260, 400, 600	3	1140 (518)
150, 260, 400, 600	3 with B	1200 (545)
800, 1000, 1200	3	1680 (762)
800, 1000, 1200	3 with B	1750 (794)
1600 – 2000	3	2495 (1132)
1600 – 2000	3 with B	2675 (1213)
3000	3	2830 (1276)
3000	3 with B	3460 (1560)
3000	3	6300 (2858)
4000	3 with C	6900 (3130)

ASCO Power Technologies®

ASCO Power Technologies
50 Hanover Road
Florham Park, NJ 07932
USA

800 800 ASCO
WWW.ASCOPOWER.COM

Supplied and Supported in New Zealand and the Pacific by:



IT Power Services Limited

13A Piermark Drive, Albany
PO Box 302-714, North Harbour
Auckland, New Zealand

Phone: +64 (9) 415-5080
Fax: +64 (9) 415-5081
Email: mail@itpower.co.nz
Web: www.itpower.co.nz

Emerson Network Power.

The world leader in business-critical continuity.

■ AC Power Systems

■ Embedded Power

■ Power Switching & Controls

■ Site Monitoring

■ Connectivity

■ Integrated Cabinet Solutions

■ Precision Cooling

■ Surge & Signal Protection

■ DC Power Systems

■ Outside Plant

■ Services

EmersonNetworkPower.com

Emerson Network Power and the Emerson Network Power logo are trademarks and service marks of Emerson Electric Co. ©2008 Emerson Electric Co.

Publication 3071 R6

© July, 2008

Printed in the U.S.A.